

# Scissors and Fine Motor Skills Practice

# Ramadan

## Activity Book for Little Kids

Jameela Ho

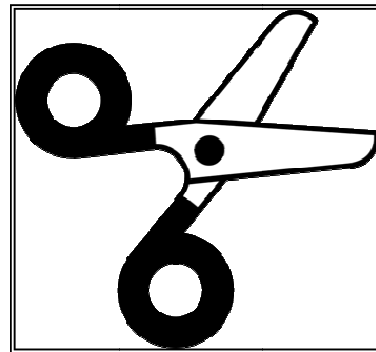
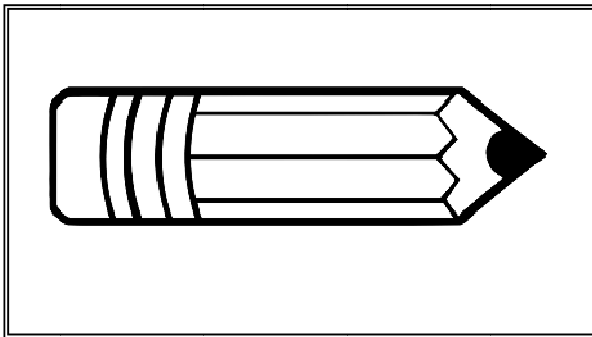

Is it Ramadan? Can you see the crescent moon? No, not yet. It's only three stars.

**3** stars

Colour the picture. Cut and paste the stars in the sky.

Tarawih is a special prayer that we pray during Ramadan. We can go to the mosque to pray it. Trace then colour in the mosque.

www.muslimcentral.com.au

Help to prepare the food by pasting the same food in each row.

Colour the pictures. Look at the food or drink in each row. Cut out and paste the picture that is the same in each row.

--	--	--	--

Is it Ramadan? Can you see the crescent moon? No, not yet. It's only one plane.

1 plane

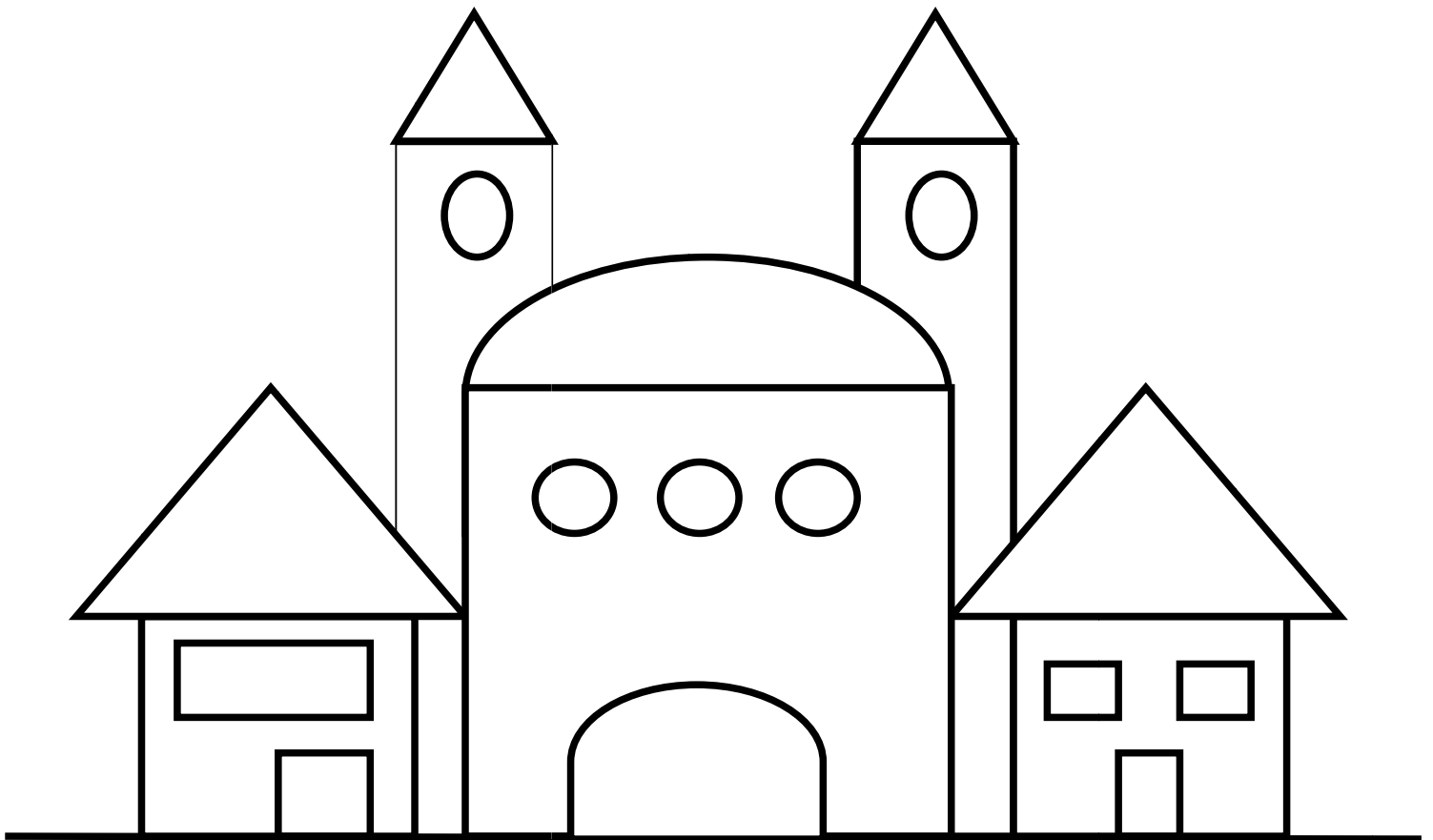

Colour the picture. Cut and paste the plane in the sky.

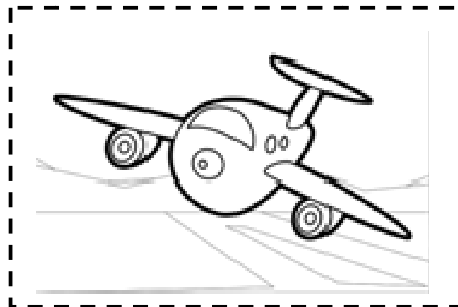

Is it Ramadan? Can you see the crescent moon? No, not yet. It's only two birds.

2 birds

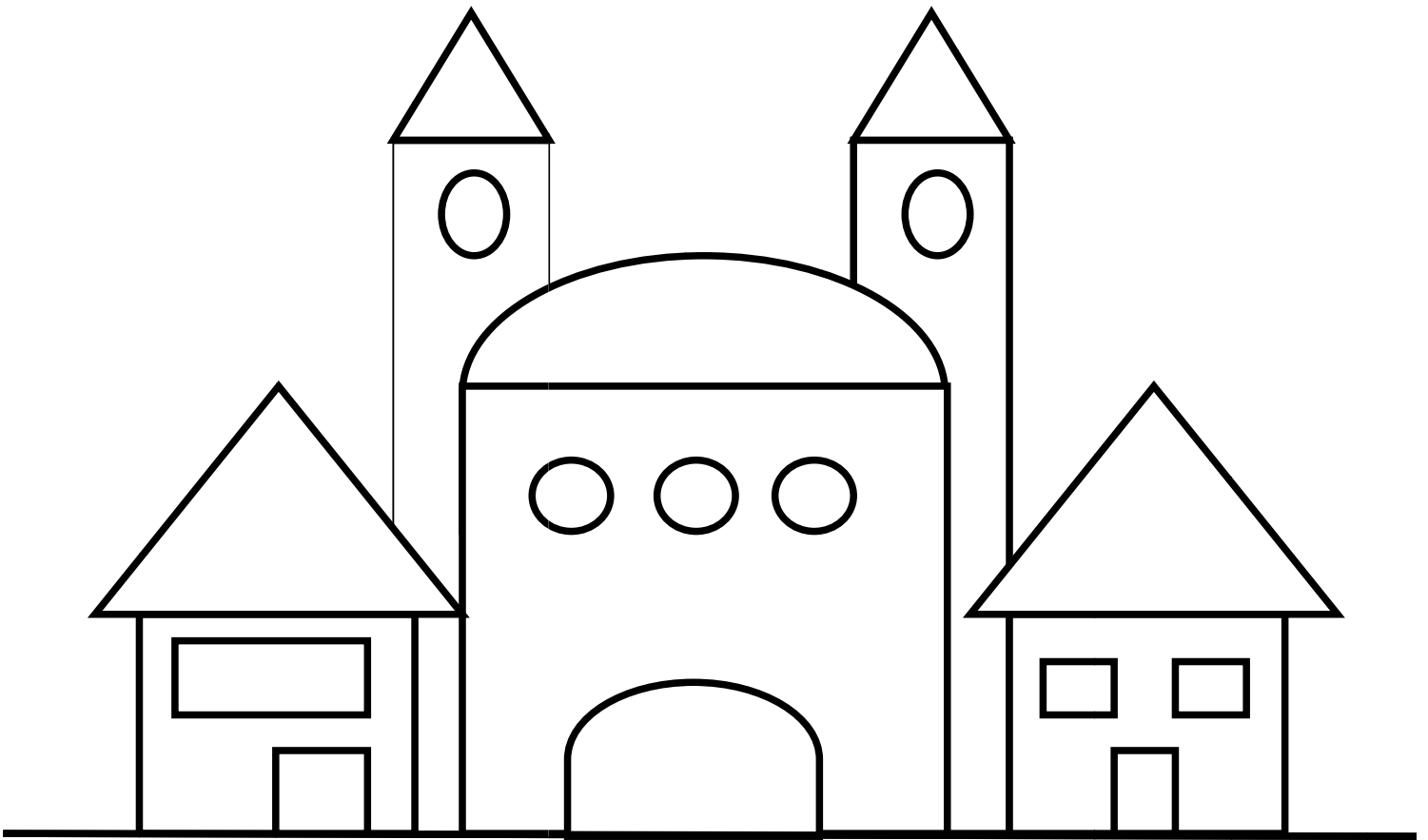

Colour the picture. Cut and paste the birds in the sky.

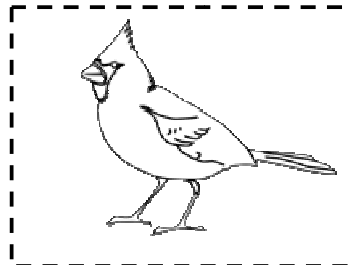
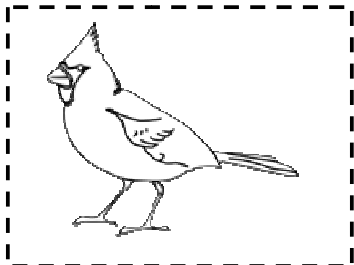

Is it Ramadan? Can you see the crescent moon? No, not yet. It's only three stars.

**3** stars

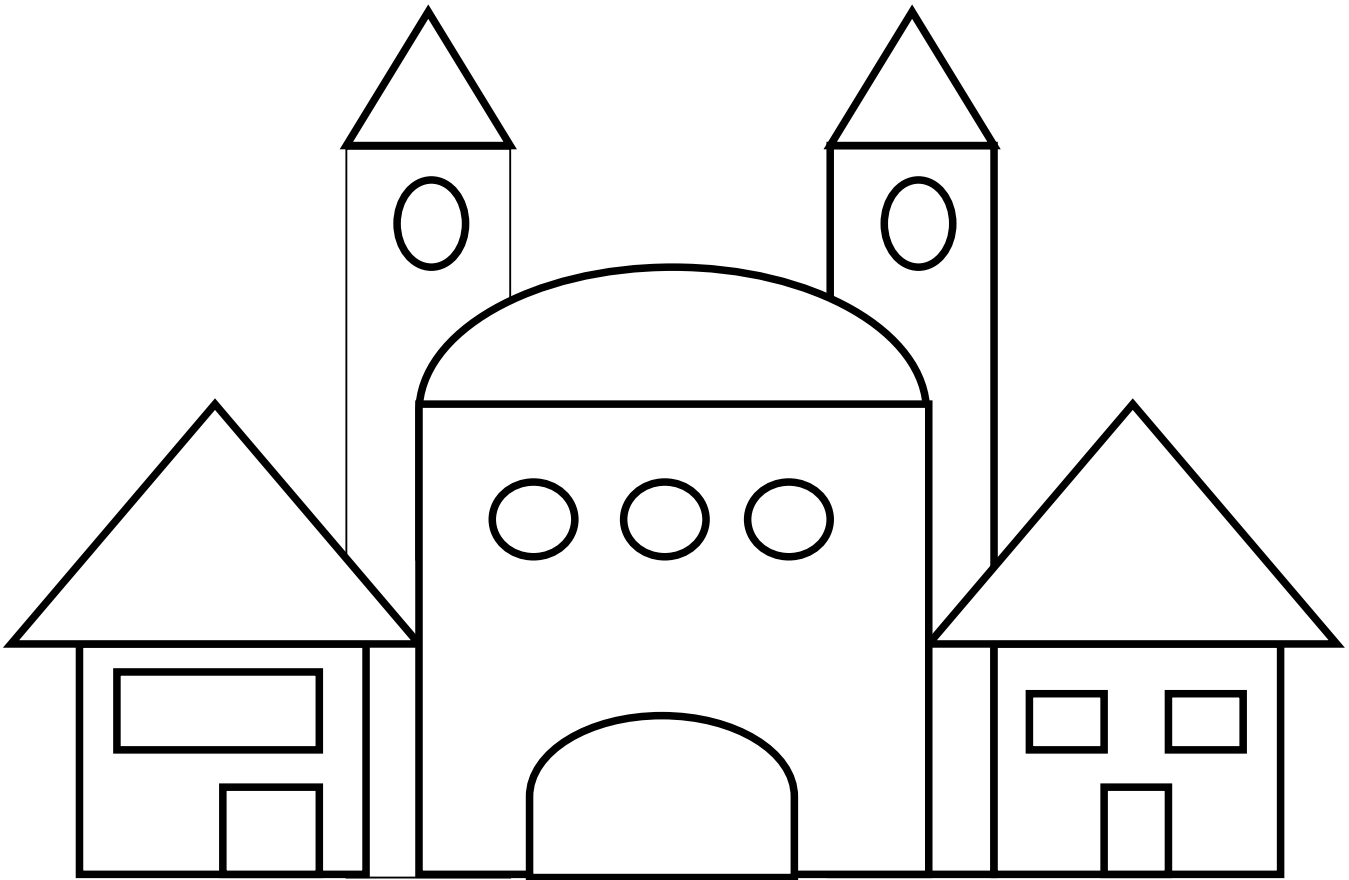

---

Colour the picture. Cut and paste the stars in the sky.

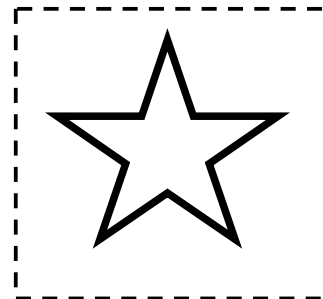
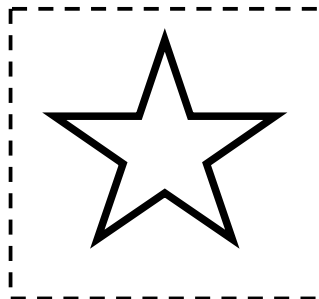
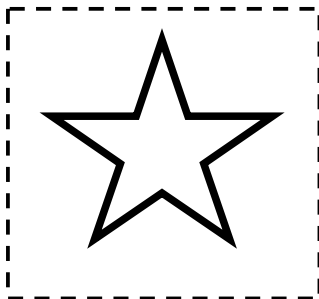



There's the crescent moon in the sky. It's Ramadan!

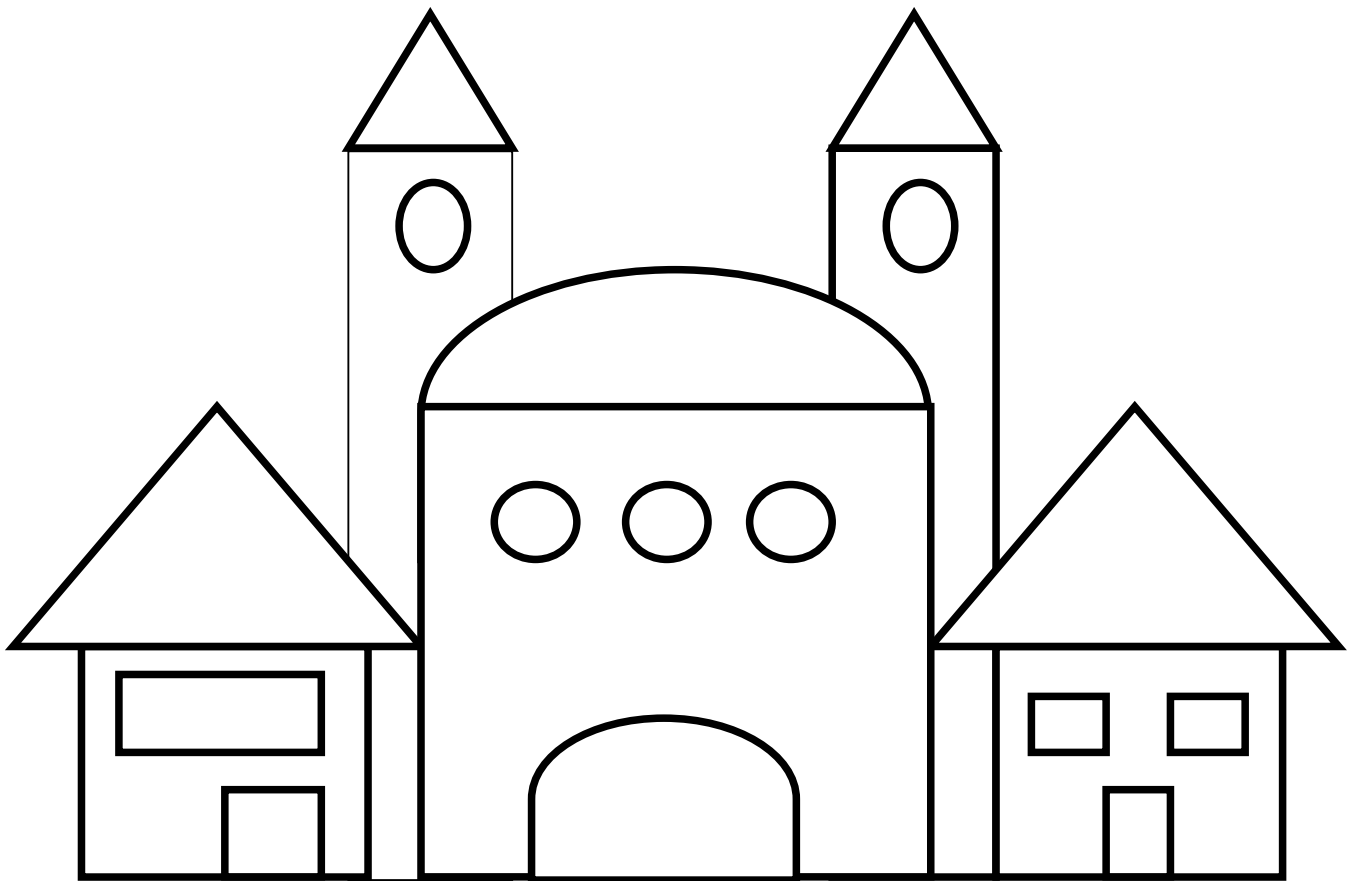

---

Colour the picture. Cut and paste the crescent moon in the sky. If you have star stickers then use them to decorate the sky.

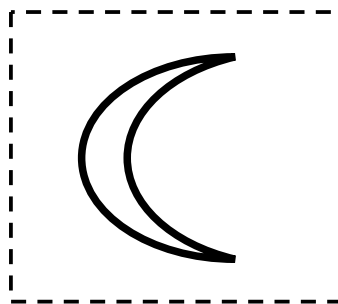

Trace the numbers. Count the things in each picture. Draw a line to the number that matches each picture.

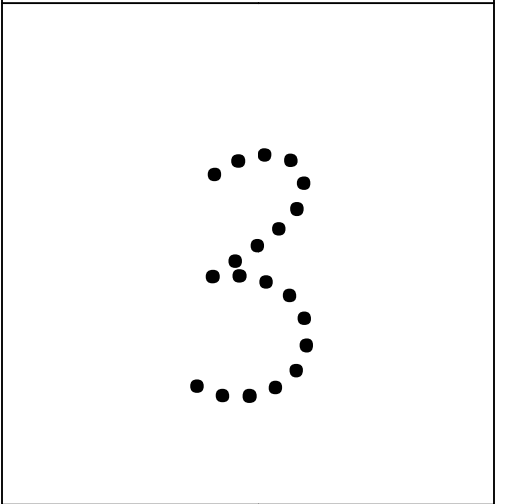
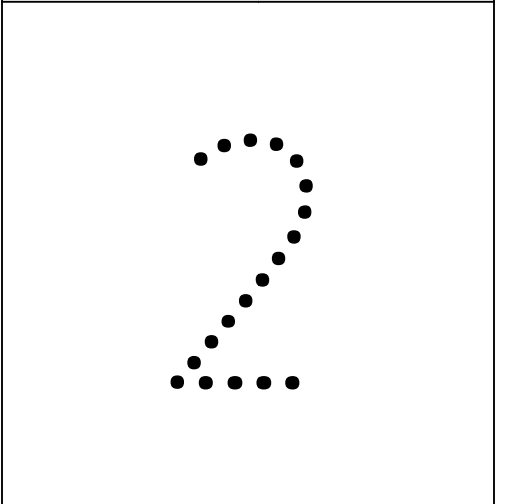
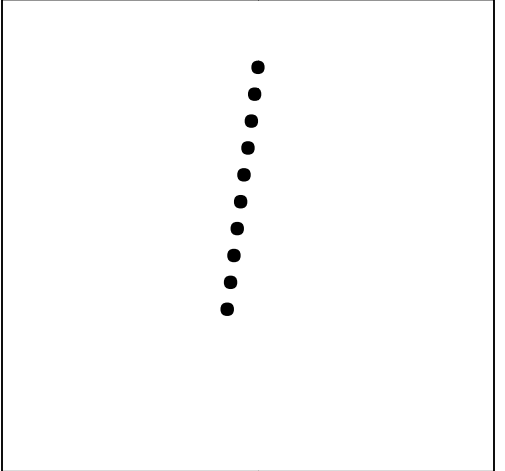
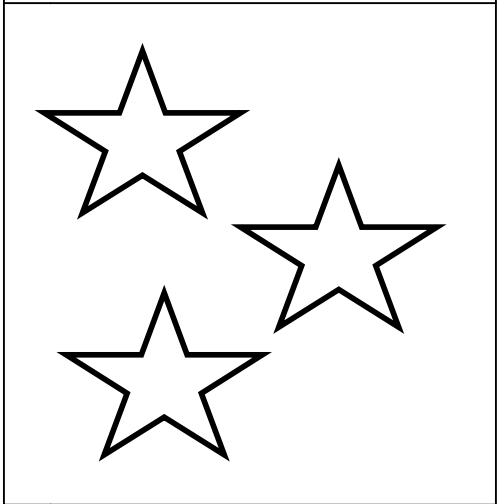
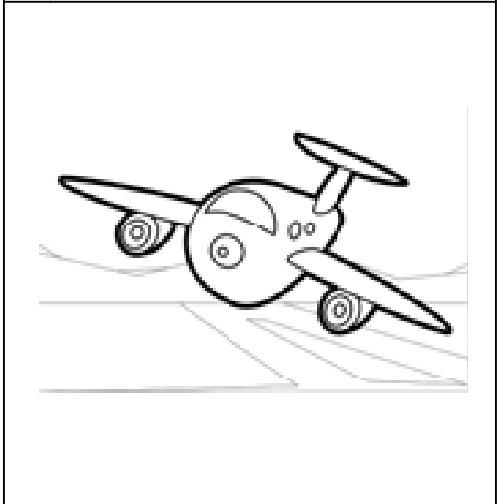
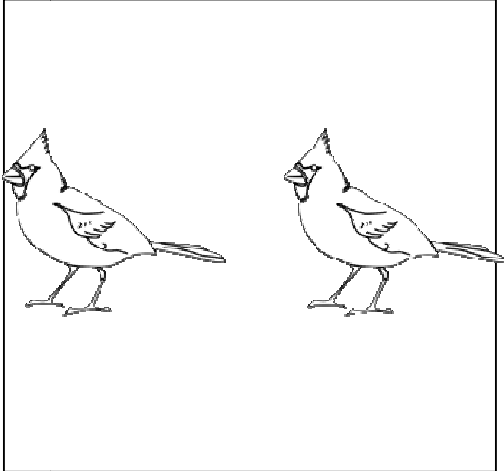

In Ramadan, we don't eat or drink during the day. Put all the food away into the fridge.



-----  
Colour the pictures. Cut out the ones that are food and drinks. Glue them onto the fridge.

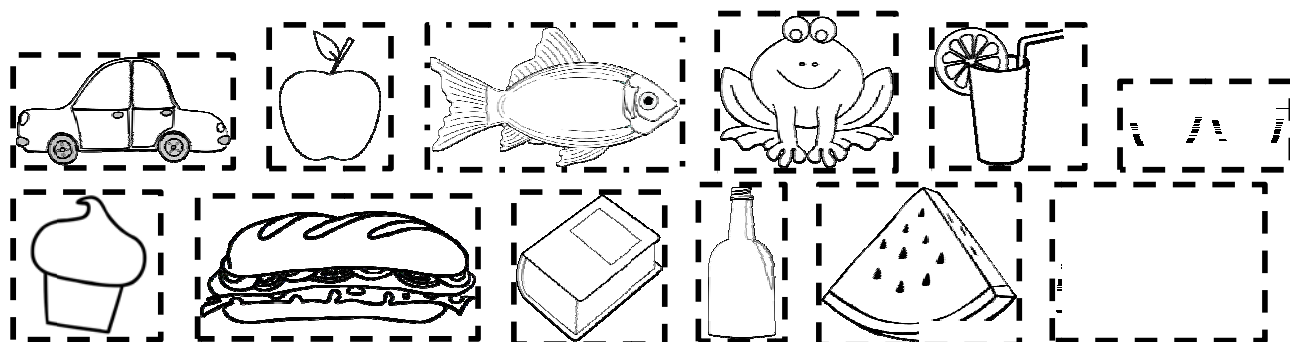

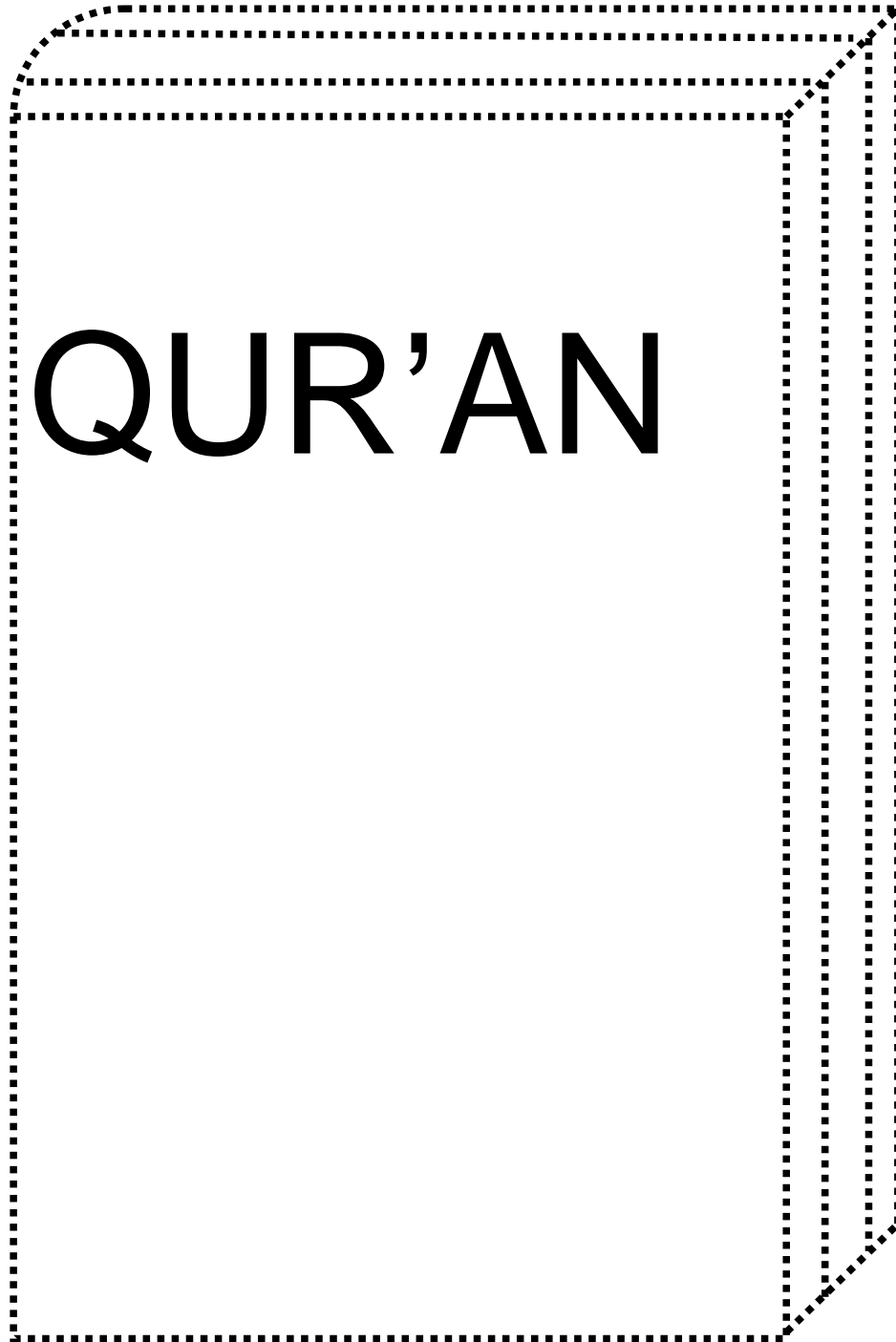

The Qur'an is the Book of Allah. We read it as much as we can during Ramadan. Trace and colour the Qur'an.

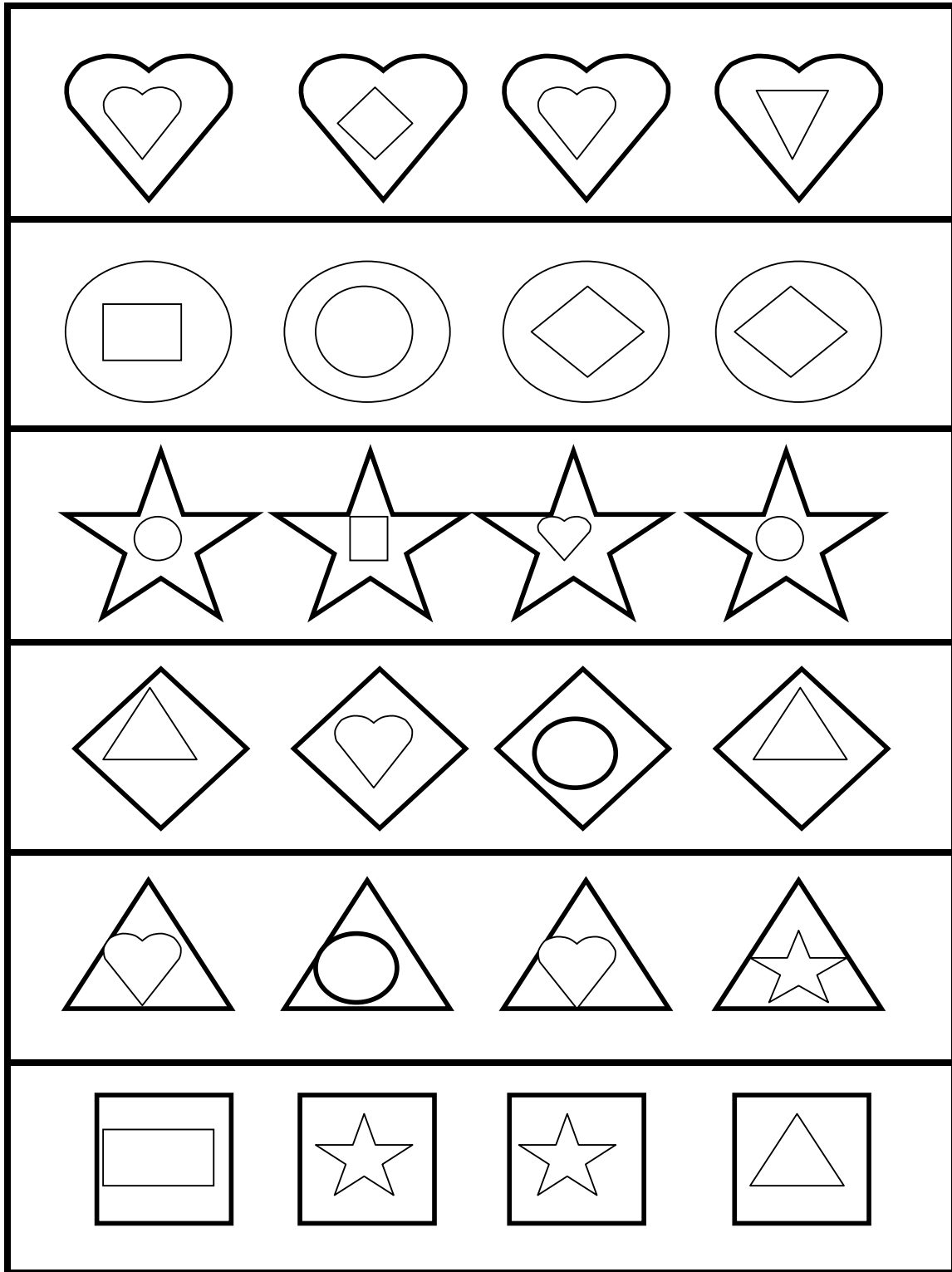

It's nearly time for iftar to break our fast. Help bake some biscuits. Colour the two that are the same in each row.

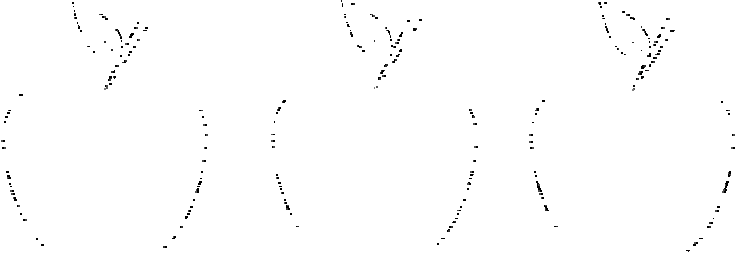

Help to prepare the food by pasting the same food in each row.

	
	

---

Colour the pictures. Look at the food or drink in each row. Cut out and paste the picture that is the same in each row.

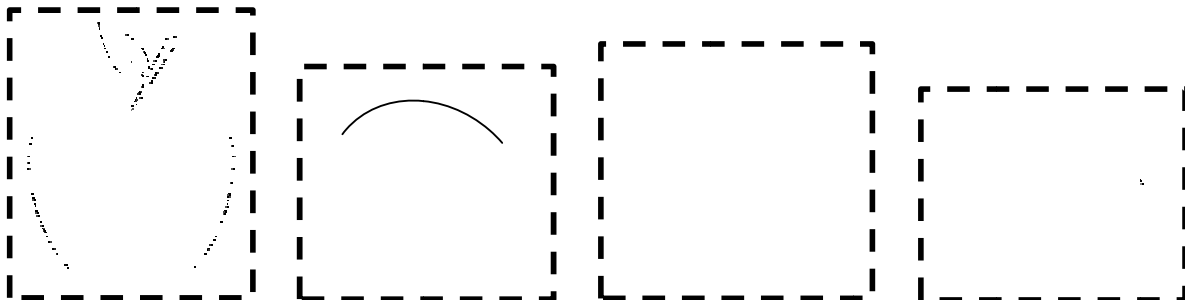

It's iftar – time to break our fast. How many dates and glasses of water can you see on the table?

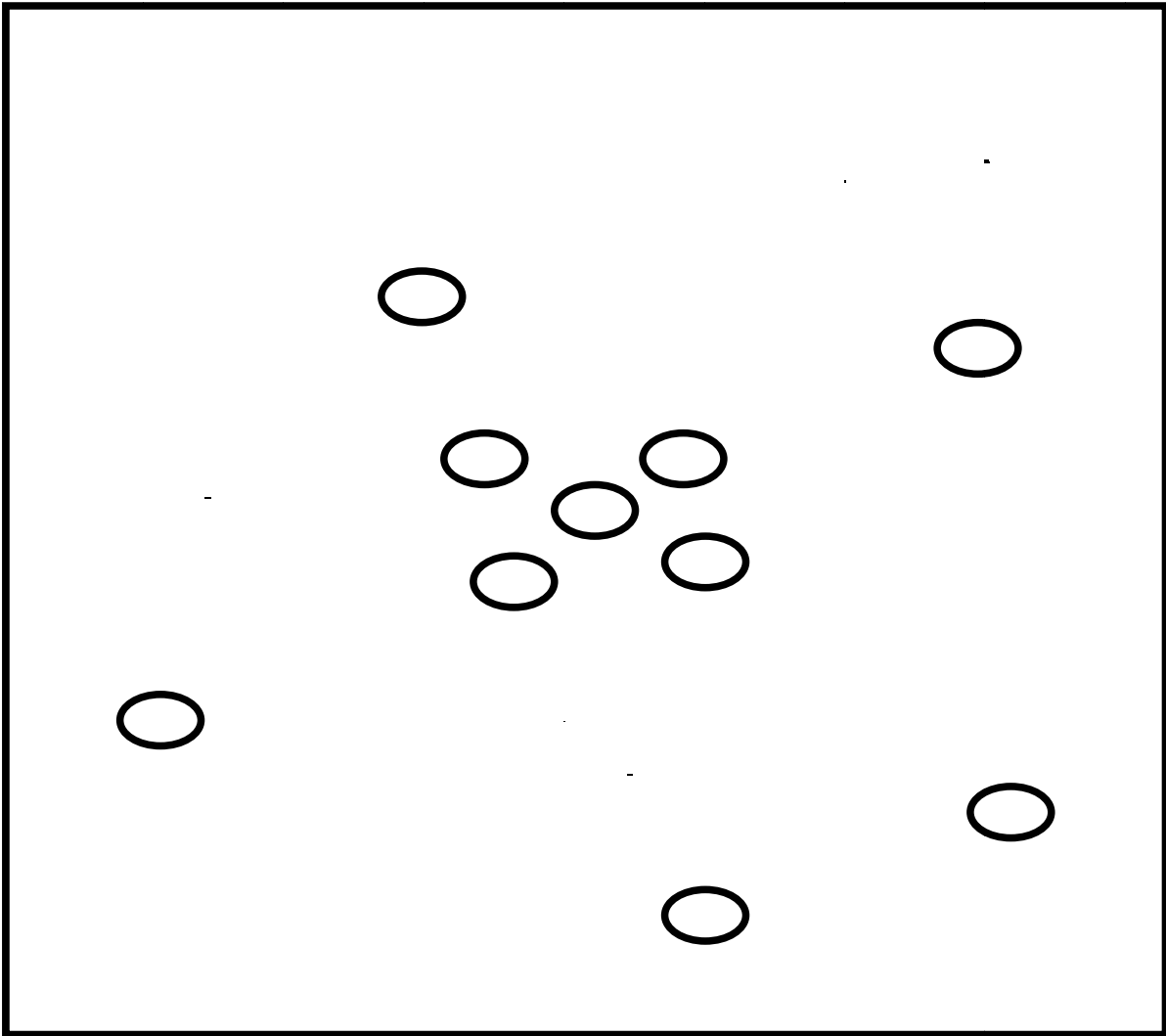

How many can you find?

\_\_\_\_\_

\_\_\_\_\_

It's time to eat! Choose and colour the food that is different in each row to eat.

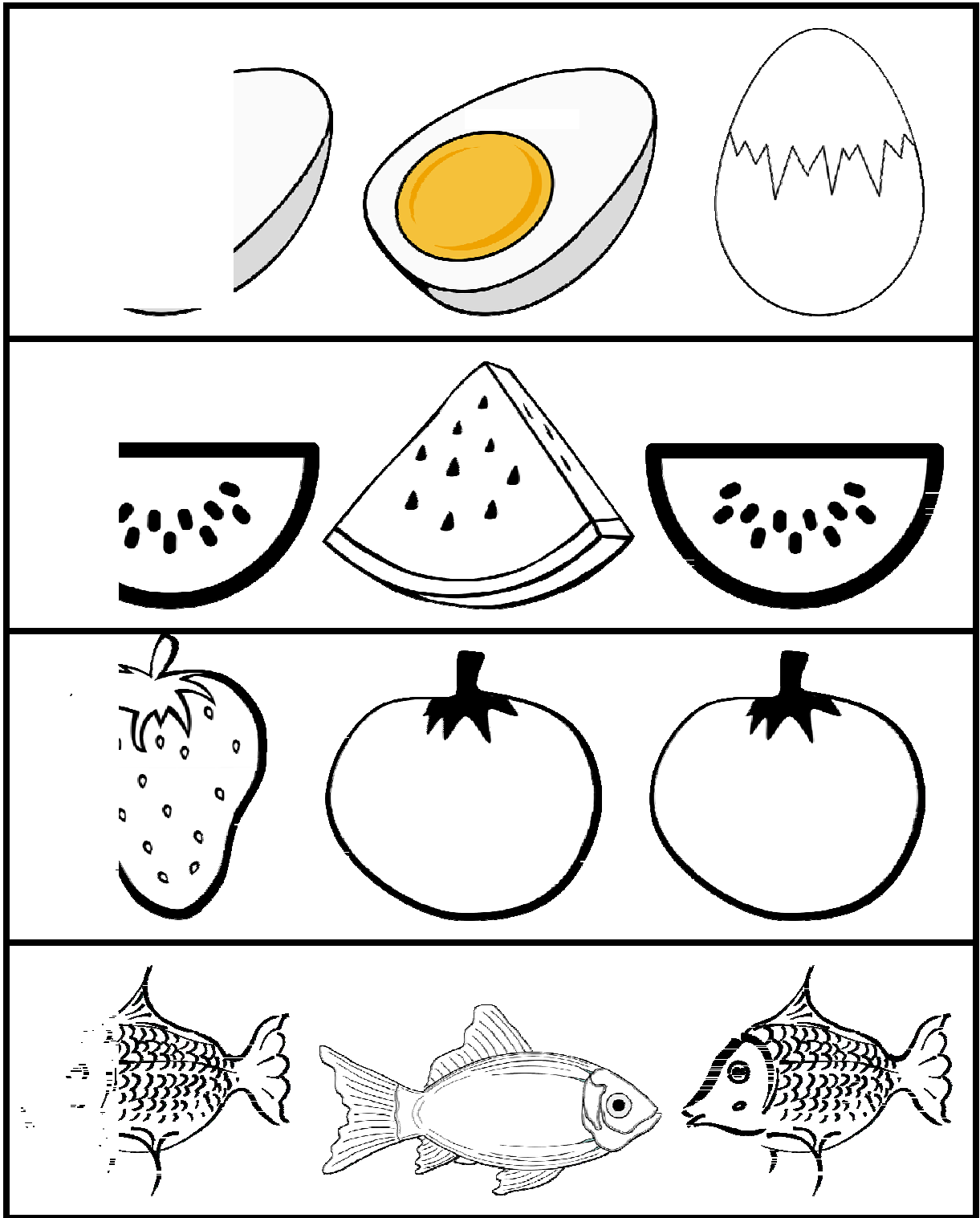



Tarawih is a special prayer that we pray during Ramadan. We can go to the mosque to pray it. Trace then colour in the mosque.

